

SFH 102mm DEFLECTION ISOLATION HANGER

TYPE	L	H	W	A	B	Dmax
4-100/1600	68	406	238	102	152	29

S-I UNITS (MM AND KG)

STANDARD RATINGS

TYPE	SIZE	COIL	COIL FREE HT	O.D.	RATED LOAD
SFH	4-100	GRAY	254	143	45
SFH	4-250	BLUE	254	143	114
SFH	4-500	GREEN	254	143	227
SFH	4-750	BLACK	254	143	341
SFH	4-1000	RED	254	143	454
SFH	4-1250	BROWN	254	143	568
SFH	4-1600	ORANGE	254	143	726

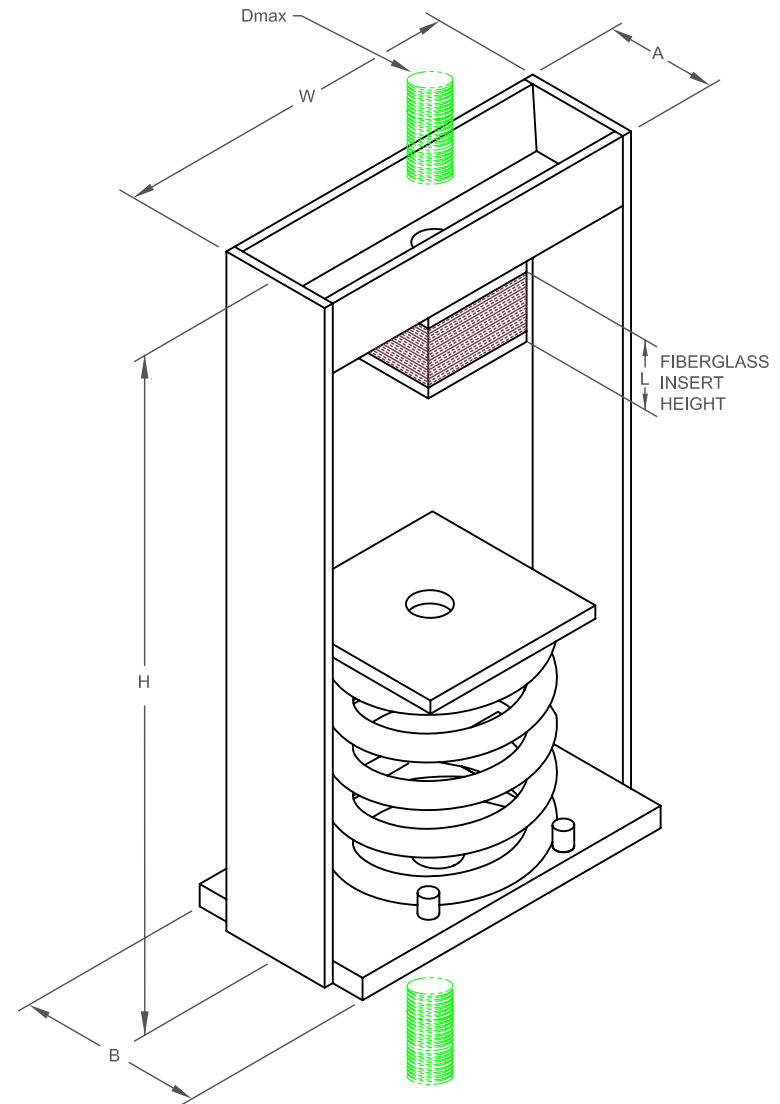

SPECIFICATIONS:

- SPRING ELEMENTS AND BRACKETS ARE POWDER COATED
- LOAD PLATES ARE BRIGHT ZINC PLATED
- ISOLATION HANGERS HAVE A TYPICAL OVERLOAD OF 50%
- ISOLATION HANGERS HAVE A MINIMUM K_x/K_y RATIO OF 1.5
- SPRING ELEMENTS ARE SAFE AT SOLID LOADING
- HANGER BRACKETS WILL CARRY (5) TIMES OVERLOAD WITHOUT FAILURE
- HANGER BRACKETS WILL ALLOW 30° ROD MISALIGNMENT WITHOUT SHORT CIRCUITING



KINETICS NOISE CONTROL, INC
6300 IRELAN PL,
DUBLIN, OH 43017 USA
Ph: 614 889-0480, Fax: 614 889-0540
www.kineticsnoise.com

Model:
SFH
4-100/1600

By: JMJ
Date: 10/28/03
Revised: 08/23/04 / BB

Drawing No:
S-03.35-41(M)