

SFH 2" DEFLECTION ISOLATION HANGER

TYPE	L	H	W	A	Dmax
2-35/220	1.13	7.38	3.69	2.25	0.50

I-P UNITS (INCHES AND POUNDS)

STANDARD RATINGS

TYPE	SIZE	COIL	COIL FREE HT	O.D.	RATED LOAD
SFH	2-35	BLUE	4.13	1.75	35
SFH	2-70	GREEN	4.13	1.75	70
SFH	2-120	GRAY	4.13	1.75	120
SFH	2-220	BROWN	4.13	1.75	220

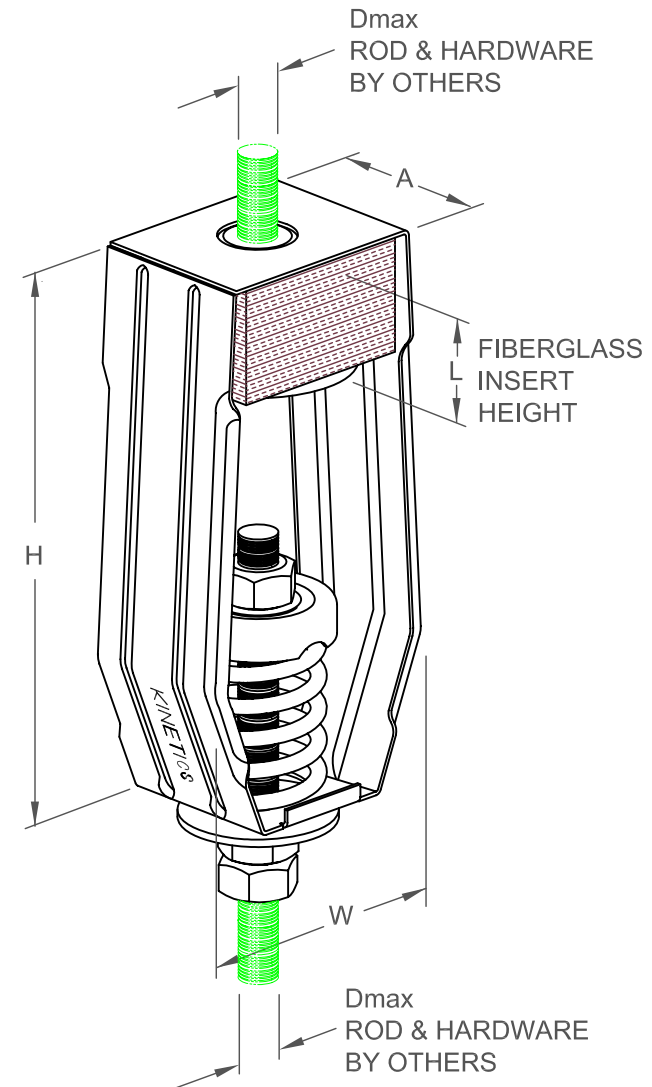

SPECIFICATIONS:

- SPRING ELEMENTS AND BRACKETS ARE POWDER COATED
- LOAD PLATES ARE BRIGHT ZINC PLATED
- ISOLATION HANGERS HAVE A TYPICAL OVERLOAD OF 50%
- ISOLATION HANGERS HAVE A MINIMUM K_x/K_y RATIO OF 1.1
- SPRING ELEMENTS ARE SAFE AT SOLID LOADING
- HANGER BRACKETS WILL CARRY (5) TIMES OVERLOAD WITHOUT FAILURE
- HANGER BRACKETS WILL ALLOW 30° ROD MISALIGNMENT WITHOUT SHORT CIRCUITING
- "NO SHORT" STEP CAP



KINETICS NOISE CONTROL, INC
 6300 IRELAN PL,
 DUBLIN, OH 43017 USA
 Ph: 614 889-0480, Fax: 614 889-0540
 www.kineticsnoise.com

Model:
SFH-2-35/220

By: JMJ
 Date: 10/24/03
 Revised: 08/23/04 / BB

Drawing No:
S-03.35-21