

SFH 51mm DEFLECTION ISOLATION HANGER

TYPE	L	H	W	A	Dmax
2-260/1200	51	218	142	92	25

S-I UNITS (MM AND KG)

STANDARD RATINGS

TYPE	SIZE	COIL	COIL FREE HT	O.D.	RATED LOAD
SFH	2-260	BLUE	107	76	118
SFH	2-465	GREEN	107	76	211
SFH	2-720	BLACK	107	76	327
SFH	2-850	WHITE	108	76	386
SFH	2-1025	BEIGE	108	76	466
SFH	2-1200	CHROME	114	76	545

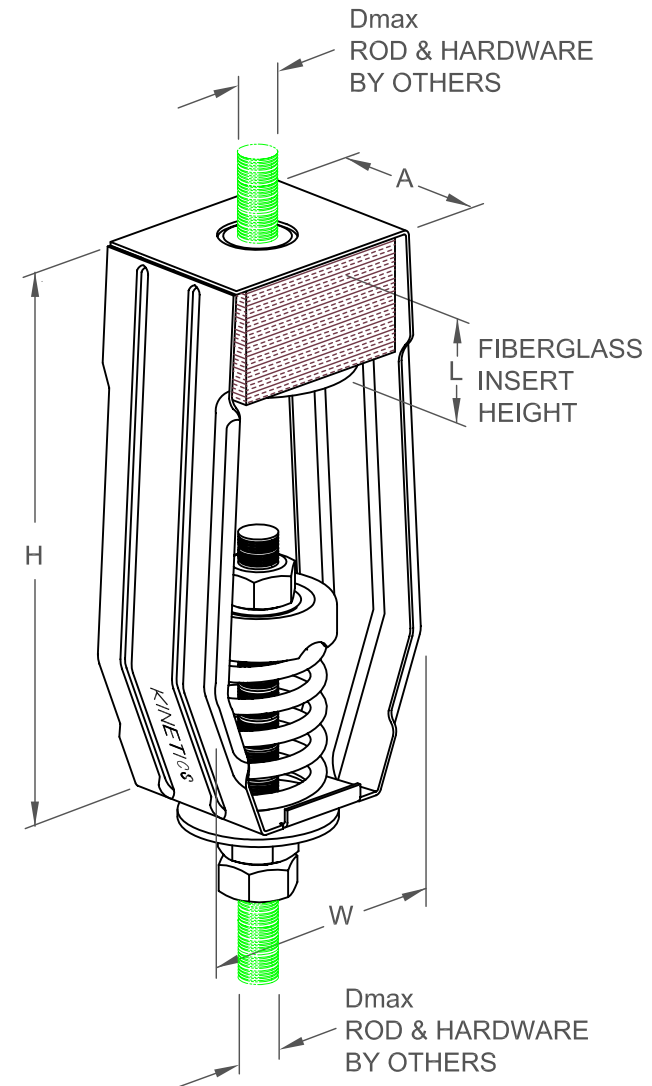

SPECIFICATIONS:

- SPRING ELEMENTS AND BRACKETS ARE POWDER COATED
- LOAD PLATES ARE BRIGHT ZINC PLATED
- ISOLATION HANGERS HAVE A TYPICAL OVERLOAD OF 50%
- ISOLATION HANGERS HAVE A MINIMUM K_x/K_y RATIO OF 1.3
- SPRING ELEMENTS ARE SAFE AT SOLID LOADING
- HANGER BRACKETS WILL CARRY (5) TIMES OVERLOAD WITHOUT FAILURE
- HANGER BRACKETS WILL ALLOW 30° ROD MISALIGNMENT WITHOUT SHORT CIRCUITING
- "NO SHORT" STEP CAP



KINETICS NOISE CONTROL, INC
 6300 IRELAN PL,
 DUBLIN, OH 43017 USA
 Ph: 614 889-0480, Fax: 614 889-0540
www.kineticsnoise.com

Model:
**SFH-2-
 260/1200**

By: **JMJ**
 Date: **10/24/03**
 Revised: **08/23/04 / BB**

Drawing No:
S-03.35-22(M)