

# SFH 52mm DEFLECTION ISOLATION HANGER

TYPE	L	H	W	A	Dmax
1-250/1000	38	218	142	92	25

S-I UNITS (MM AND KG)

## STANDARD RATINGS

TYPE	SIZE	COIL	COIL FREE HT	O.D.	RATED LOAD
SFH	1-250	BLUE	107	76	114
SFH	1-450	GREEN	107	76	205
SFH	1-625	BLACK	107	76	284
SFH	1-800	GRAY	107	76	364
SFH	1-1000	RED	107	76	455

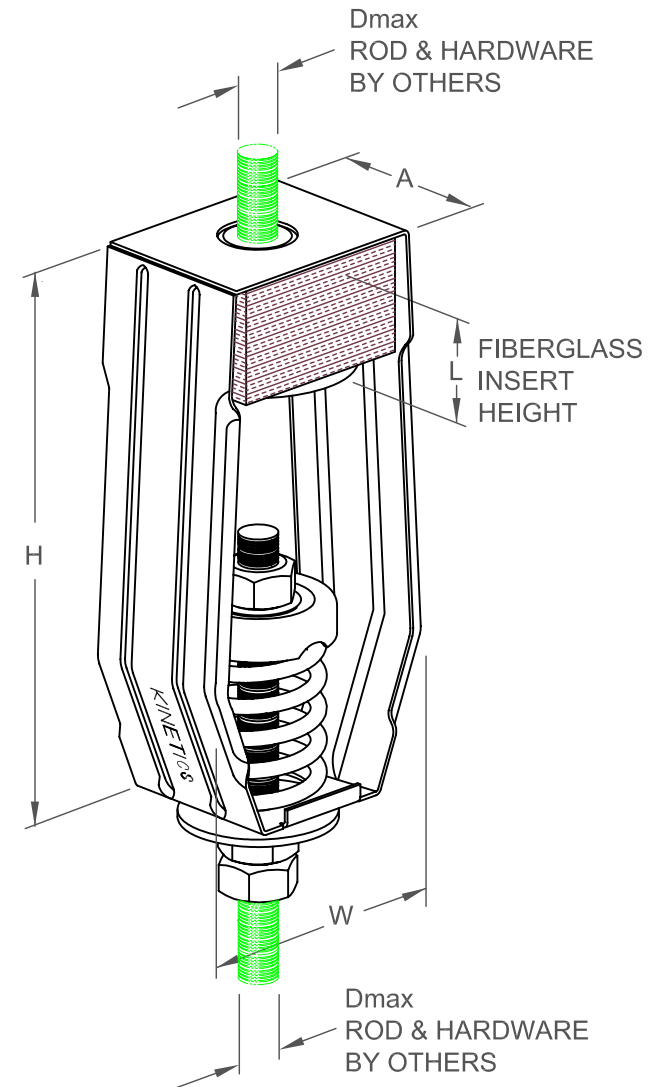

## SPECIFICATIONS:

- SPRING ELEMENTS AND BRACKETS ARE POWDER COATED
- LOAD PLATES ARE BRIGHT ZINC PLATED
- ISOLATION HANGERS HAVE A TYPICAL OVERLOAD OF 50%
- ISOLATION HANGERS HAVE A MINIMUM  $K_x/K_y$  RATIO OF 1.4
- SPRING ELEMENTS ARE SAFE AT SOLID LOADING
- HANGER BRACKETS WILL CARRY (5) TIMES OVERLOAD WITHOUT FAILURE
- HANGER BRACKETS WILL ALLOW 30° ROD MISALIGNMENT WITHOUT SHORT CIRCUITING
- "NO SHORT" STEP CAP



KINETICS NOISE CONTROL, INC  
 6300 IRELAN PL,  
 DUBLIN, OH 43017 USA  
 Ph: 614 889-0480, Fax: 614 889-0540  
[www.kineticsnoise.com](http://www.kineticsnoise.com)

Model:  
**SFH**  
 1-250/1000

By: JMJ  
 Date: 10/24/03  
 Revised: 08/23/04 / BB

Drawing No:  
**S-03.35-12(M)**