

SFH 1" DEFLECTION ISOLATION HANGER

TYPE	L	H	W	A	Dmax
1-1250/1700	1.50	8.59	5.58	3.63	1.00

I-P UNITS (INCHES AND POUNDS)

STANDARD RATINGS

TYPE	SIZE	COIL	COIL FREE HT	O.D.	RATED LOAD
SFH	1-1250	BROWN	4.20	3.00	1250
SFH	1-1700	ORANGE	4.20	3.00	1700

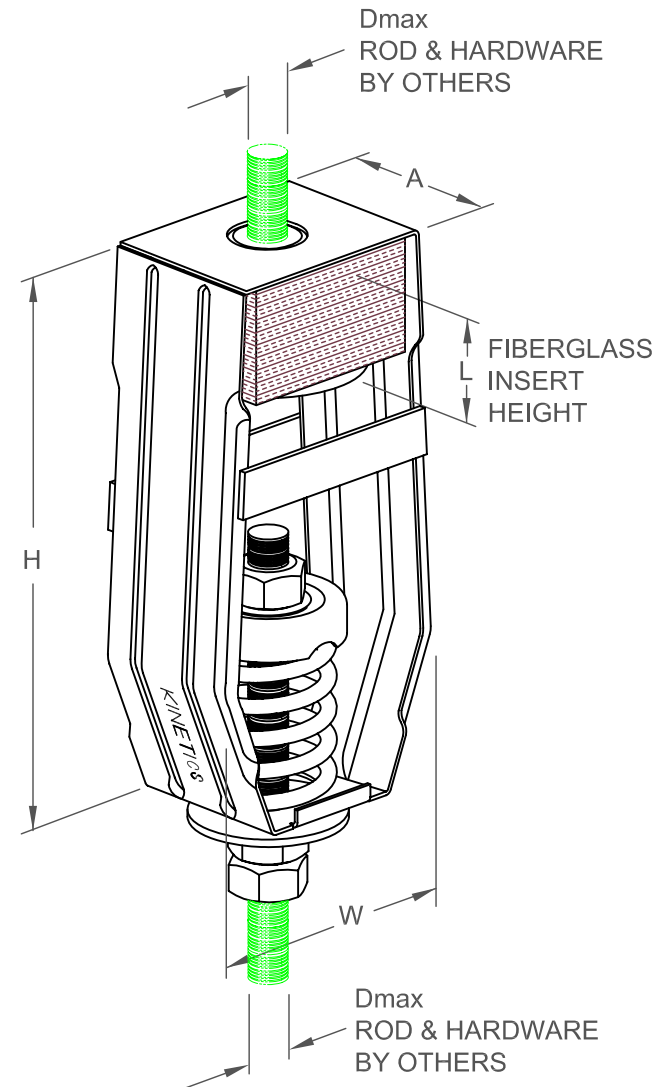

SPECIFICATIONS:

- SPRING ELEMENTS AND BRACKETS ARE POWDER COATED
- LOAD PLATES ARE BRIGHT ZINC PLATED
- ISOLATION HANGERS HAVE A TYPICAL OVERLOAD OF 50%
- ISOLATION HANGERS HAVE A MINIMUM K_x/K_y RATIO OF 1.2
- SPRING ELEMENTS ARE SAFE AT SOLID LOADING
- HANGER BRACKETS WILL CARRY (5) TIMES OVERLOAD WITHOUT FAILURE
- HANGER BRACKETS WILL ALLOW 30° ROD MISALIGNMENT WITHOUT SHORT CIRCUITING
- "NO SHORT" STEP CAP



KINETICS NOISE CONTROL, INC
 6300 IRELAN PL,
 DUBLIN, OH 43017 USA
 Ph: 614 889-0480, Fax: 614 889-0540
 www.kineticsnoise.com

Model:
SFH
1-1250/1700

By: **JMJ**
 Date: **10/24/03**
 Revised: **08/23/04 / BB**

Drawing No:
S-03.35-13