

FIGURE 2
STEEL ATTACHMENT

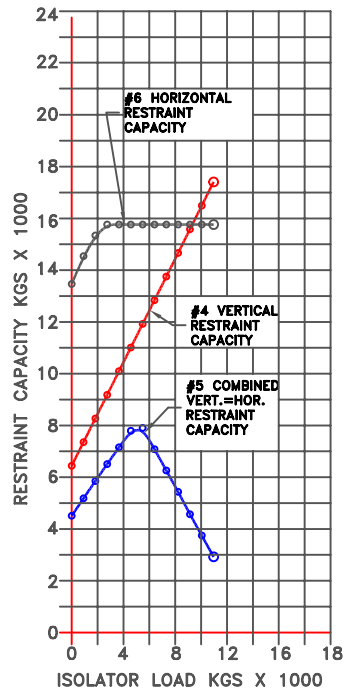
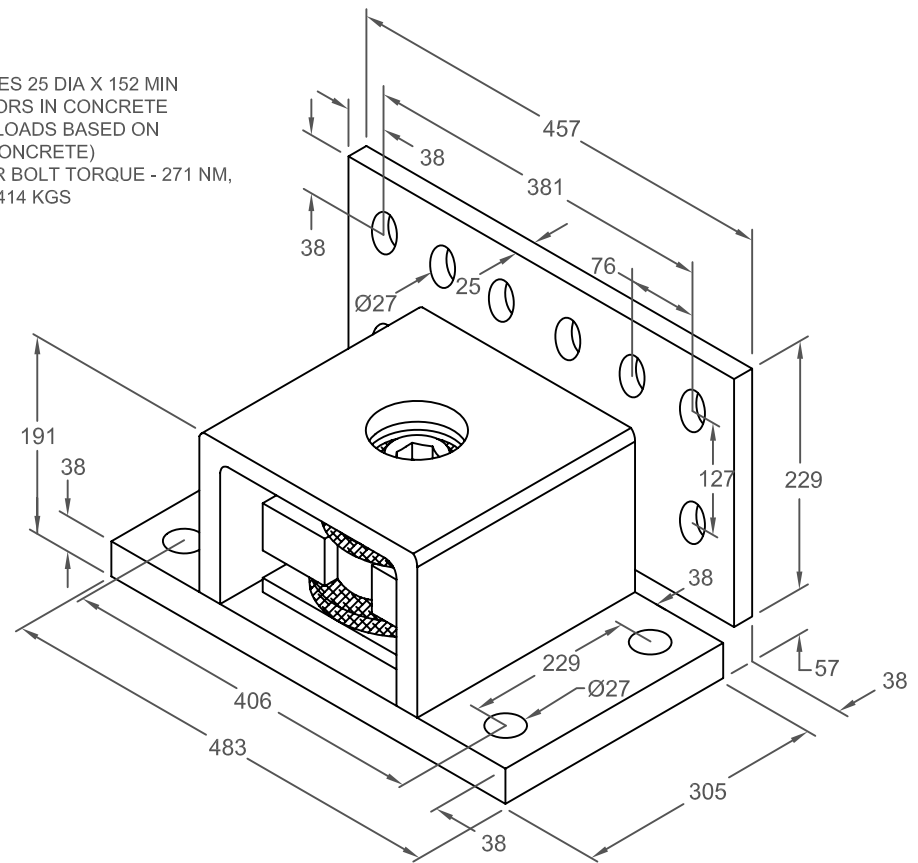

FIGURE 3
CONCRETE ATTACHMENT

FMSF REQUIRES 25 DIA X 152 MIN EMBED ANCHORS IN CONCRETE (ALLOWABLE LOADS BASED ON 144 kPA MIN CONCRETE) FMSF ANCHOR BOLT TORQUE - 271 NM, PULL TEST - 2414 KGS



RESTRAINT CAPACITY ENVELOPE GENERATION

RESTRAINT ONLY (NO SPRING ELEMENT)

1) READ THE ANCHORED (CONCRETE) OR BOLTED (STEEL) ENVELOPES DIRECTLY FROM FIGURE 1 AT RIGHT

RESTRAINT WITH SPRING SUPPORT ELEMENT (ISOLATOR/RESTRAINT)

- 1) DETERMINE THE MAXIMUM EQUIPMENT LOAD SUPPORTED BY THE ISOLATOR(S)
- 2) IF THROUGH-BOLTED (STEEL), REFER TO FIGURE 3. IF ANCHORED (CONCRETE), REFER TO FIGURE 2.
- 3) PLOT THE VERTICAL RESTRAINT CAPACITY FROM CURVE #1 (FIGURE 2) OR #4 (FIGURE 3) ON THE VERTICAL AXIS OF FIGURE 1.
- 4) PLOT THE HORIZONTAL RESTRAINT CAPACITY FROM CURVE #3 (FIGURE 2) OR #6 (FIGURE 3) ON THE HORIZONTAL AXIS OF FIGURE 1.
- 5) PLOT THE COMBINED RESTRAINT CAPACITY FROM CURVE #2 (FIGURE 2) OR #5 (FIGURE 3) AT THE POINT ON FIGURE 1 WHERE THE VERTICAL AND HORIZONTAL FORCES BOTH MATCH THIS VALUE.
- 6) CONNECTING THESE POINTS CREATES AN ENVELOPE THAT SHOWS THE RESTRAINT'S CAPACITY WHEN SUBJECTED TO EQUIPMENT SUPPORT AND SEISMIC LOADS SIMULTANEOUSLY.
- 7) FOR THE RESTRAINT TO BE ADEQUATE, ALL WORST CASE SEISMIC LOADS MUST FALL WITHIN THE ENVELOPE.

SPECIFICATIONS:

- 3 AXIS RESTRAINT WITH REPLACEABLE NEOPRENE SNUBBING ELEMENTS
- HOT DIPPED GALVANIZED
- HOUSINGS MAY BE USED FOR BLOCKING DURING EQUIPMENT ERECTION
- CAN BE USED WITH OR WITHOUT SPRING COIL

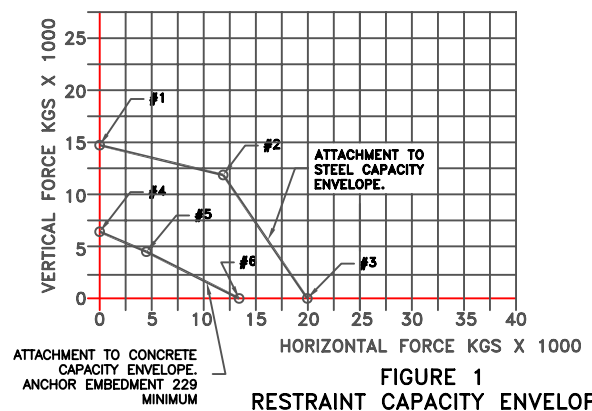
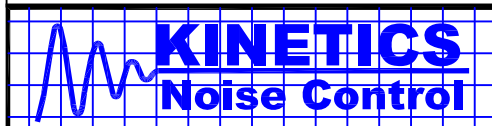

FIGURE 1
RESTRAINT CAPACITY ENVELOPE



KINETICS NOISE CONTROL, INC
6300 IRELAN PL,
DUBLIN, OH 43017 USA
Ph: 614 889-0480, Fax: 614 889-0540
www.kineticsnoise.com

Model:
FMSF
RESTRAINT

By: JMJ
Date: 10/13/03
Revised: /

Drawing No:
S-01-40.600(m)