

**FDS 1" DEFLECTION ISOLATOR  
IP UNITS (INCHES AND POUNDS)**

TYPE	L	T	D	H	Z
1-35/805	2.63	0.25	0.69	4.19	0.38
1-250/3500	3.88	0.38	1.00	5.44	0.38

STANDARD RATINGS		SPRING COIL					
TYPE	SIZE	COLOR		FREE		RATED	
		OUTER	INNER	HT.	O.D.	LOAD	DEFL.
FDS	1-35	BLUE		3.19	1.75	35	1.52
FDS	1-70	GREEN		3.19	1.75	70	1.36
FDS	1-120	GRAY		3.19	1.75	120	1.18
FDS	1-220	BROWN		3.19	1.75	220	1.07
FDS	1-370	ORANGE		3.19	1.75	370	0.96
FDS	1-500	BEIGE		3.19	1.75	500	1.00
FDS	1-600	CHROME		3.19	1.75	600	1.00
FDS	1-700	BEIGE	WHITE	3.19	1.75	700	1.00
FDS	1-805	CHROME	WHITE	3.19	1.75	805	1.01
FDS	1-250	BLUE		4.20	3.00	250	1.79
FDS	1-450	GREEN		4.20	3.00	450	1.54
FDS	1-625	BLACK		4.20	3.00	625	1.44
FDS	1-800	GRAY		4.20	3.00	800	1.31
FDS	1-1000	RED		4.20	3.00	1000	1.15
FDS	1-1250	BROWN		4.20	3.00	1250	1.09
FDS	1-1700	ORANGE		4.20	3.00	1700	0.95
FDS	1-2200	ORANGE	GRAY	4.20	3.00	2200	1.00
FDS	1-2465	BLUE		4.20	3.00	2465	1.00
FDS	1-2865	BLUE	GRAY	4.20	3.00	2865	1.00
FDS	1-3500	BLUE	BROWN	4.20	3.00	3500	1.00

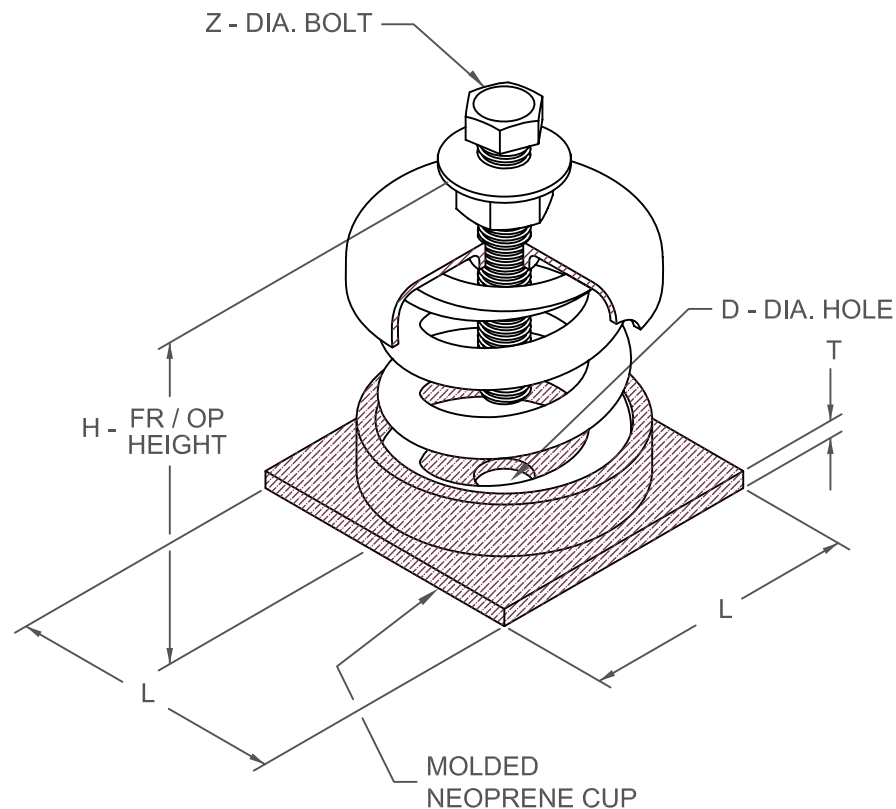

**SPECIFICATIONS:**

- FREE STANDING COIL SPRING ISOLATOR
- POWDER COATED SPRING ELEMENT
- OTHER METALLIC COMPONENTS BRIGHT ZINC PLATED
- MINIMUM OVERLOAD OF 50%.
- MINIMUM Kx/Ky RATIO OF 1.0.
- ALL ELEMENTS SAFE AT SOLID LOADING.
- ALL THREADED MEMBERS ARE AMERICAN STANDARD



KINETICS NOISE CONTROL, INC  
6300 IRELAN PL,  
DUBLIN, OH 43017 USA  
Ph: 614 889-0480, Fax: 614 889-0540  
www.kineticsnoise.com

Model:  
**FDS-1-35/3500**

By: **JMJ**  
Date: **12/21/01**  
Revised: **6/19/03 / JMJ**

Drawing No:  
**S-01.20-11**