

FDS 25 mm DEFLECTION ISOLATOR

S-I UNITS (mm AND kg)

TYPE	L	T	D	H	Z
1-35/805	67	6	17	106	10
1-250/3500	98	10	25	138	10

STANDARD RATINGS		SPRING COIL					
TYPE	SIZE	COLOR		FREE		RATED	
		OUTER	INNER	HT.	O.D.	LOAD	DEFL.
FDS	1-35	BLUE		81	44	16	39
FDS	1-70	GREEN		81	44	32	35
FDS	1-120	GRAY		81	44	54	30
FDS	1-220	BROWN		81	44	100	27
FDS	1-370	ORANGE		81	44	168	24
FDS	1-500	BEIGE		81	44	227	25
FDS	1-600	CHROME		81	44	272	25
FDS	1-700	BEIGE	WHITE	81	44	318	25
FDS	1-805	CHROME	WHITE	81	44	365	26
FDS	1-250	BLUE		107	76	113	45
FDS	1-450	GREEN		107	76	204	39
FDS	1-625	BLACK		107	76	283	37
FDS	1-800	GRAY		107	76	363	33
FDS	1-1000	RED		107	76	454	29
FDS	1-1250	BROWN		107	76	567	28
FDS	1-1700	ORANGE		107	76	771	24
FDS	1-2200	ORANGE	GRAY	107	76	998	26
FDS	1-2465	BLUE		107	76	1118	25
FDS	1-2865	BLUE	GRAY	107	76	1300	25
FDS	1-3500	BLUE	BROWN	107	76	1588	25

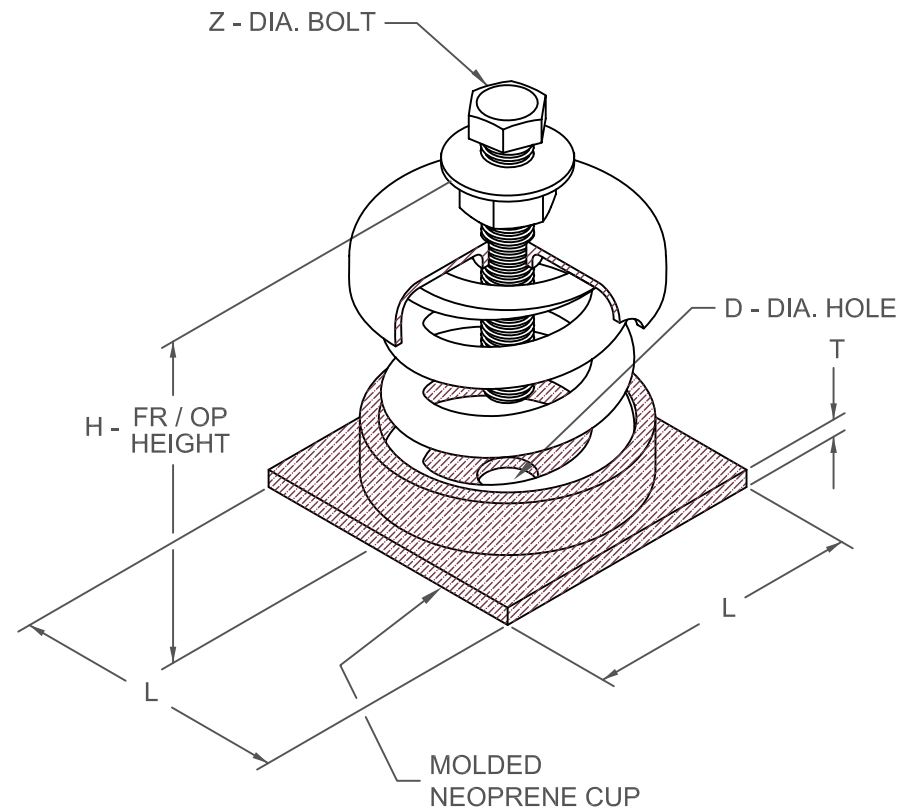

SPECIFICATIONS:

- FREE STANDING COIL SPRING ISOLATOR
- POWDER COATED SPRING ELEMENT
- OTHER METALLIC COMPONENTS BRIGHT ZINC PLATED
- MINIMUM OVERLOAD OF 50%.
- MINIMUM Kx/Ky RATIO OF 1.0.
- ALL ELEMENTS SAFE AT SOLID LOADING.
- ALL THREADED MEMBERS ARE AMERICAN STANDARD



KINETICS NOISE CONTROL, INC
 6300 IRELAN PL,
 DUBLIN, OH 43017 USA
 Ph: 614 889-0480, Fax: 614 889-0540
 www.kineticsnoise.com

Model:
FDS-1-35/3500

By: JMJ
 Date: 12/21/01
 Revised: 6/19/03 / JMJ

Drawing No:
S-01.20-11(M)